

TAPPI CAVITÀ
FVTA-**-000000

Tipo

Tappi chiusura cavità C26-C10

10.2

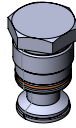
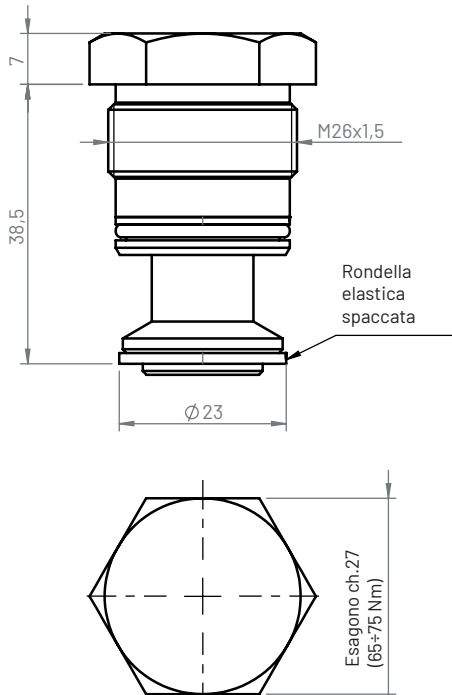

Schema idraulico

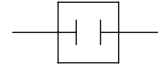

Caratteristiche tecniche

Pressione max	350 bar
Coppia di serraggio	65±75 Nm
Peso	0,1 kg
Materiale O-Ring	NBR 70
Cavità	C26 (vedi pag. 20.3)

Esempio di ordinazione

FVTA - 26 - 000000

Tappo cavità: **FVTA**
Dimensione: **26** (cavità C26)

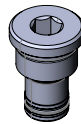
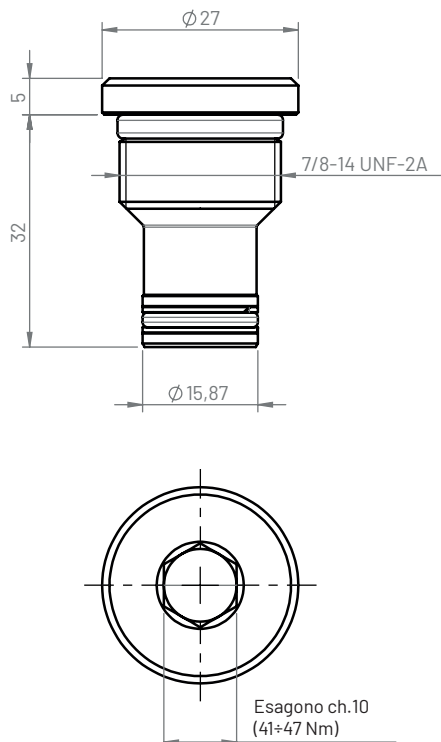

Schema idraulico

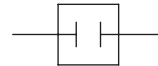

Caratteristiche tecniche

Pressione max	350 bar
Coppia di serraggio	41±47 Nm
Peso	0,08 kg
Materiale O-Ring	NBR 70
Cavità	C10 (vedi pag. 20.3)

Esempio di ordinazione

FVTA - 10 - 000000

Tappo cavità: **FVTA**
Dimensione: **10** (cavità C10)

